

GRUA TORRE / TOWER CRANE

GRUE A TOUR / БАШЕННЫЙ КРАН /

KULE VINÇ / رافعة برجية /

J480PA



EN14439
C25

UNE-EN-ISO 9001

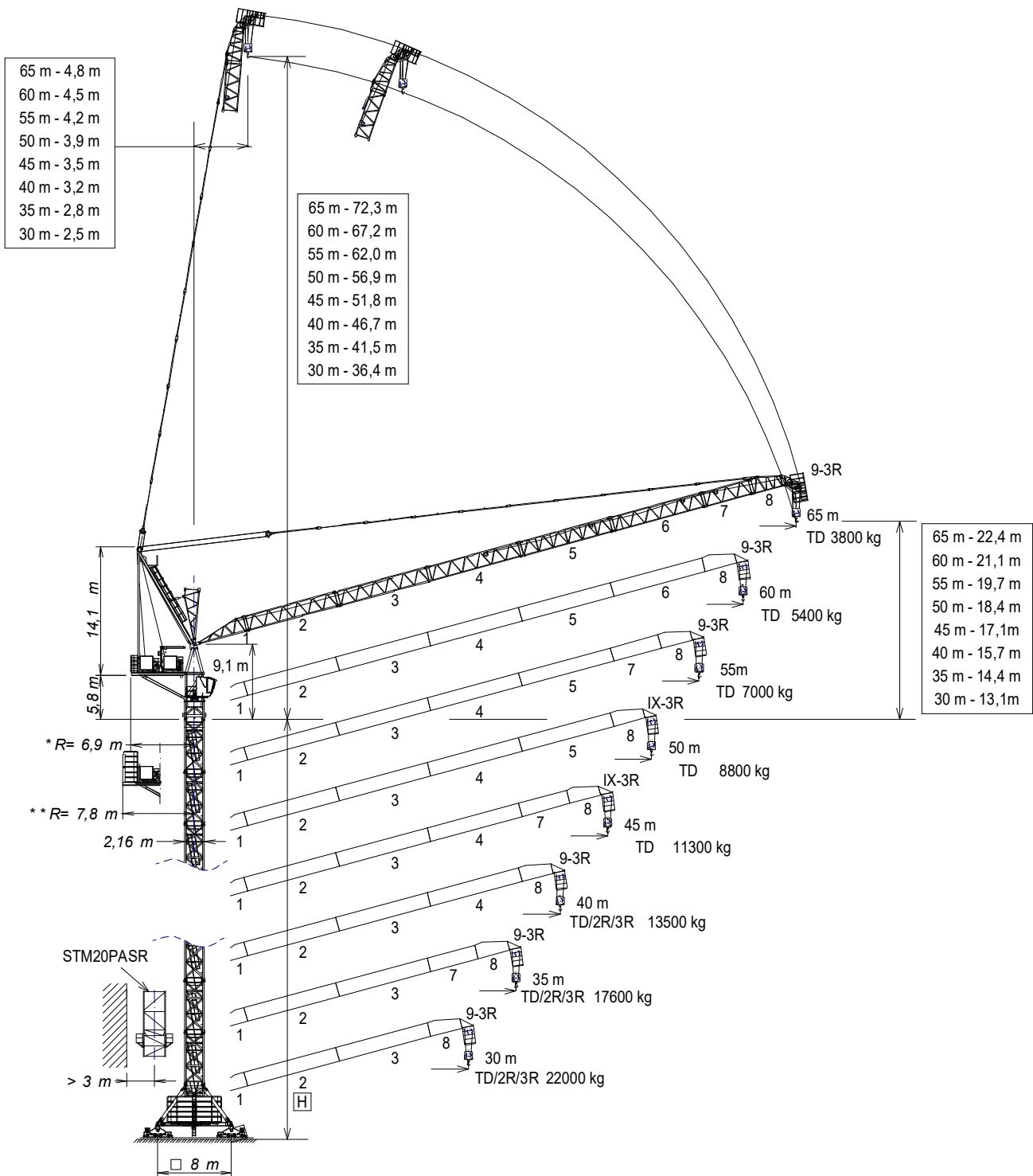



* Contrapesos metálicos / Steel Counterweight	Tramo pluma 1 / Jib section 1	206.40.000	BSR18-20-5,6	204.20.000
** Contrapesos de hormigón / Concrete counterweights	Tramo pluma 2 / Jib section 2	206.41.200	ASR20	160.21.200
Tramo pluma / Jib section / Tronçon de flèche / Секция стрелы / Bom bölümü / أجزاء الذراع	Tramo pluma 3 / Jib section 3	206.42.200	TSR20	153.31.800
	Tramo pluma 4 / Jib section 4	206.43.000	TSR20-5,6	204.31.000
	Tramo pluma 5 / Jib section 5	206.44.000	ABH100C	170.23.000
	Tramo pluma 6 / Jib section 6	206.45.000	ABH100H	156.23.500
	Tramo pluma 7 / Jib section 7	206.46.000		
	Tramo pluma 8 / Jib section 8	206.47.200		
	Tramo pluma 9-3R / Jib section 9-3R	206.48.000		



Fecha / Date: 05/07/2021



FEM 1005 - C25



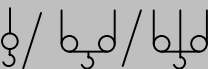

Reservado el derecho a modificaciones sin previo aviso. Declinamos toda responsabilidad derivada de la información proporcionada / Subject to modification, without prior notice. This information is supplied without liability / L'entreprise se réserve le droit de procéder à des modifications sans préavis. Nous déclinons toute responsabilité quant aux informations fournies / Мы оставляем за собой право на внесение изменений без предварительного уведомления. Мы снимаем с себя любую ответственность в отношении предоставленной информации / Önceden bildirilmeksizin değiştirilme hakkı saklıdır. Verilen bilgiler için hiçbir sorumluluk kabul etmemekteyiz / حقوق التغيير محفوظة دون إشعار مسبق. دون أدنى مسؤولية عن المعلومات المقدمة

 TD (t)		Cargas máximas / Maximum loads / Charges maximales / Максимальные нагрузки / Maksimum yük / أقصى حمولة TD - 12t								
 [m]	TD 12t @ (m)	Alcance del gancho [m] / Hook reach [m] / Portée du crochet (m) / Радиус действия крюка (m) Kancanın yüksekliği (m) / مدى الخطاف								
		30	35	40	45	50	55	60	65	
65 m	41,1	12,0	12,0	12,0	10,1	8,0	6,4	5,0	3,8	
60 m	41,9	12,0	12,0	12,0	10,5	8,5	6,8	5,4	-	
55 m	42,2	12,0	12,0	12,0	10,7	8,6	7,0	-	-	
50 m	42,4	12,0	12,0	12,0	10,8	8,8	-	-	-	
45 m	43,5	12,0	12,0	12,0	11,3	-	-	-	-	
40 m	40,0	12,0	12,0	12,0	-	-	-	-	-	
35 m	35,0	12,0	12,0	-	-	-	-	-	-	
30 m	30,0	12,0	-	-	-	-	-	-	-	

 TD / 2R / 3R (t)		Cargas máximas / Maximum loads / Charges maximales / Максимальные нагрузки / Maksimum yük / أقصى حمولة TD / 2R / 3R (t)											
 [m]	3R 36t @ (m)	2R 24t @ (m)	TD 12t @ (m)	Alcance del gancho [m] / Hook reach [m] / Portée du crochet (m) / Радиус действия крюка (m) Kancanın yüksekliği (m) / مدى الخطاف									
				15	20	25	30	35	40	45	50	55	60
65 m	36,3	40,3	12,0	12,0	12,0	12,0	12,0	12,0	9,6	7,6	5,9	4,5	3,3
60 m	26,4	41,0	24,0	24,0	24,0	19,9	15,6	12,4	9,9	7,9	6,3	4,9	-
55 m	26,4	41,3	24,0	24,0	24,0	20,0	15,7	12,6	10,1	8,1	6,5	-	-
50 m	19,3	26,4	41,5	36,0	34,4	25,7	20,0	15,8	12,7	10,2	8,3	-	-
45 m	19,6	26,9	42,5	36,0	35,1	26,4	20,5	16,4	13,2	10,8	-	-	-
40 m	19,7	27,1	40,0	36,0	35,3	26,6	20,8	16,6	13,5	-	-	-	-
35 m	20,2	27,9	35,0	36,0	36,0	27,6	21,8	17,6	-	-	-	-	-
30 m	20,3	28,1	30,0	36,0	36,0	27,9	22,0	-	-	-	-	-	-

 TD		Alcance del gancho [m] / Hook reach [m] / Portée du crochet (m) / Радиус действия крюка (m) Kancanın yüksekliği (m) / مدى الخطاف										
 [m]	2R 18t @ (m)	TD 9t @ (m)	Alcance del gancho [m] / Hook reach [m] / Portée du crochet (m) / Радиус действия крюка (m) Kancanın yüksekliği (m) / مدى الخطاف									
			25	30	35	40	45	50	55	60	65	
65 m	31,7	46,4	18,0	18,0	15,3	12,0	9,6	7,6	5,9	4,5	3,3	













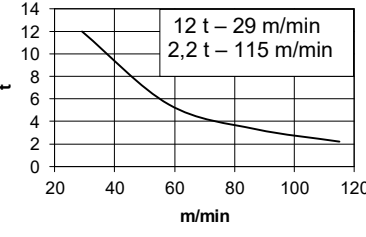
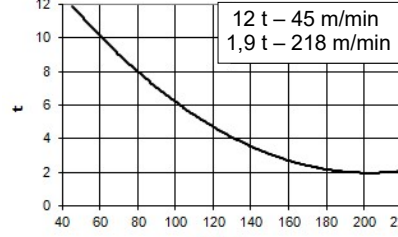

 TD		Alcance del gancho [m] / Hook reach [m] / Portée du crochet (m) / Радиус действия крюка (m) Kancanın yüksekliği (m) / مدى الخطاف									
 [m]	3R 30t @ (m)	2R 20t @ (m)	TD 10t @ (m)	Alcance del gancho [m] / Hook reach [m] / Portée du crochet (m) / Радиус действия крюка (m) Kancanın yüksekliği (m) / مدى الخطاف							
				20	25	30	35	40	45	50	55
55 m	22,4	30,1	45,5	30,0	25,9	20,0	15,7	12,6	10,1	8,1	6,5

Fecha / Date: 05/07/2021

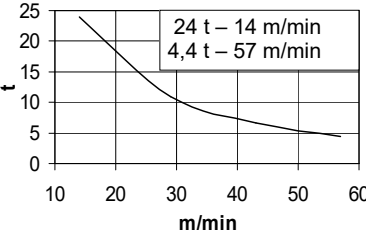
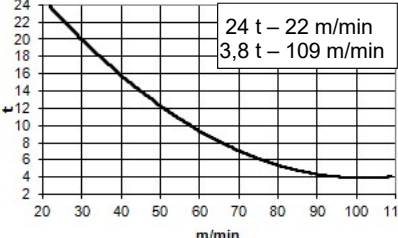
 FEM 1005 - C25

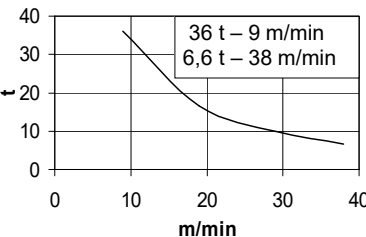
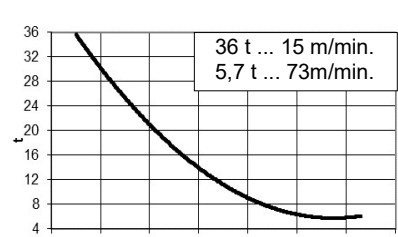

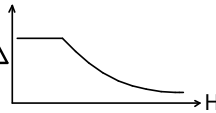
Reservado el derecho a modificaciones sin previo aviso. Declinamos toda responsabilidad derivada de la información proporcionada / Subject to modification, without prior notice. This information is supplied without liability / L'entreprise se réserve le droit de procéder à des modifications sans préavis. Nous déclinons toute responsabilité quant aux informations fournies / Мы оставляем за собой право на внесение изменений без предварительного уведомления. Мы снимаем с себя любую ответственность в отношении предоставленной информации / Önceden bildirilmeksizin değiştirilme hakkı saklıdır. Verilen bilgiler için hiçbir sorumluluk kabul etmemekteyiz / حقوق التغيير محفوظة دون إشعار مسبق. دون أدنى مسؤولية عن المعلومات المقدمة

<p>*opcional *optional *en option *опция *opsiyonel *اختياري</p>												
	<p>EC88115VF 65 kW</p>	<p>* EC150218VF 110 kW</p>	<p>TG4025VF 4x7,5 kW</p>	<p>OG2008VF 2x7,3 kW</p>	<p>EP10015VF 75 kW</p>	<p>TH4010 29,4 kW</p>						
			<p>0...25 m/min</p>	<p>0... 0,8 r/min sl/min</p>	<p>1,5 min</p>	<p>0,6 m/min</p>						
			<p> 400V 50Hz</p> <p>PTOTAL(EC88115VF + OG2008VF + EP10015VF) = 154,6 kW PTOTAL(*EC150218VF + OG2008VF + EP10015VF) = *199,6 kW</p>									
			<p>  </p> <p> <table border="0" style="margin-left: 20px;"> <tr> <td>H ≤ TD</td> <td>874m</td> </tr> <tr> <td>2R</td> <td>437m</td> </tr> <tr> <td>3R</td> <td>291m</td> </tr> </table> </p>				H ≤ TD	874m	2R	437m	3R	291m
H ≤ TD	874m											
2R	437m											
3R	291m											

 Viento fuera de servicio / Out of service wind / Vitesse du vent hors service / Ветровая нагрузка в покое / Rüzgar devre dışı / الريح خارج الخدمة

 Consultar / Consult / Nous consulter / Консультируемся / Danışınız / الرجوع إلى

 En servicio / In service / En service / В работе / Devrede / في الخدمة

 Fuera de servicio / Out of service / Hors service / В покое / Devre dışı / خارج الخدمة

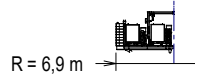

(H) ESTACIONARIA / STATIONARY / STATIONAIRE / СТАЦИОНАРНОЕ СОСТОЯНИЕ / SABIT / ثابتة

TD

▽▽	H(m)	□	⊠
30	54,6	9	1
35	50,7	9	-
40	50,7	9	-
45	45,1	8	-
50	45,1	8	-
55	45,1	8	-
60	43,4	7	1
65	39,5	7	-

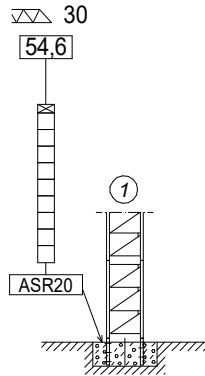

▽▽	H(m)	⊠	▨	□	⊠
30	63,3	3	1	8	-
35	61,6	3	1	7	1
40	57,7	2	1	8	-
45	57,7	3	1	7	-
50	56,0	2	1	7	1
55	52,1	3	1	6	-
60	52,1	3	1	6	-
65	46,5	2	1	6	-

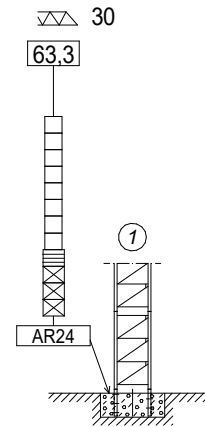

- ⊠ TSR20
- TSR20-5,6
- ▨ TR24/TSR20
- ⊠ TR24-5,6

TD / 2R / 3R

TD / 2R			
▽▽	H(m)	□	⊠
30	50,7	9	-
35	45,1	8	-
40	45,1	8	-
45	45,1	8	-
50	43,4	7	1
55	39,5	7	-
60	39,5	7	-
65	37,8	6	1

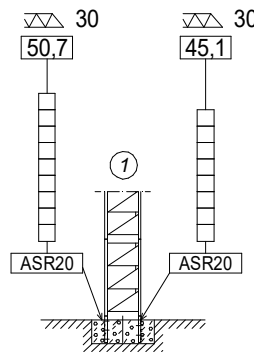

3R			
▽▽	H(m)	□	⊠
30	45,1	8	-
35	39,5	7	-
40	39,5	7	-
45	39,5	7	-
50	39,5	7	-
55	39,5	7	-

- ⊠ TSR20
- TSR20-5,6
- ▨ TR24/TSR20
- ⊠ TR24-5,6

TD / 2R					
▽▽	H(m)	⊠	▨	□	⊠
30	63,3	3	1	8	-
35	61,6	4	1	6	1
40	57,7	3	1	7	-
45	57,7	3	1	7	-
50	56,0	3	1	6	1
55	52,1	3	1	6	-
60	50,4	3	1	5	1
65	46,5	2	1	6	-

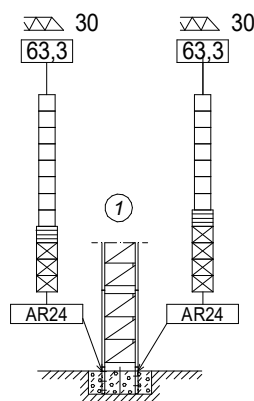

3R					
▽▽	H(m)	⊠	▨	□	⊠
30	63,3	4	1	7	-
35	61,6	4	1	6	1
40	57,7	4	1	6	-
45	56,0	3	1	6	1
50	52,1	3	1	6	-
55	52,1	3	1	6	-

H = Máxima altura de torre sin arriostrar (m).
 Maximum tower height without fastening (m).
 Hauteur maximale de tour sans ancrage (m).
 Максимальная высота башни без крепления (м).
 Desteksiz maksimum kule yüksekliği (m)
 أقصى ارتفاع للبرج بدون ربط (م)



Fecha / Date: 05/07/2021

FEM 1005 - C25

Reservado el derecho a modificaciones sin previo aviso. Declinamos toda responsabilidad derivada de la información proporcionada / Subject to modification, without prior notice. This information is supplied without liability / L'entreprise se réserve le droit de procéder à des modifications sans préavis. Nous déclinons toute responsabilité quant aux informations fournies / Мы оставляем за собой право на внесение изменений без предварительного уведомления. Мы снимаем с себя любую ответственность в отношении предоставленной информации / Önceden bildirilmeksizin değiştirilme hakkı saklıdır. Verilen bilgiler için hiçbir sorumluluk kabul etmemekteyiz حقوق التغيير محفوظة دون إشعار مسبق. دون أدنى مسؤولية عن المعلومات المقدمة



(H) ESTACIONARIA 3 / STATIONARY 3 / STATIONAIRE / СТАЦИОНАРНОЕ СОСТОЯНИЕ / SABIT / ثابتة

TD	TD / 2R / 3R		3R																																																																																																							
<table border="1" style="margin-top: 10px;"> <thead> <tr> <th>▽▽</th> <th>H(m)</th> <th>□</th> <th>⊠</th> </tr> </thead> <tbody> <tr><td>30</td><td>57,5</td><td>9</td><td>-</td></tr> <tr><td>35</td><td>51,9</td><td>8</td><td>-</td></tr> <tr><td>40</td><td>51,9</td><td>8</td><td>-</td></tr> <tr><td>45</td><td>51,9</td><td>8</td><td>-</td></tr> <tr><td>50</td><td>51,9</td><td>8</td><td>-</td></tr> <tr><td>55</td><td>46,3</td><td>7</td><td>-</td></tr> <tr><td>60</td><td>46,3</td><td>7</td><td>-</td></tr> <tr><td>65</td><td>44,6</td><td>6</td><td>1</td></tr> </tbody> </table>	▽▽	H(m)	□	⊠	30	57,5	9	-	35	51,9	8	-	40	51,9	8	-	45	51,9	8	-	50	51,9	8	-	55	46,3	7	-	60	46,3	7	-	65	44,6	6	1	<table border="1" style="margin-bottom: 10px;"> <thead> <tr> <th colspan="4">TD / 2R</th> </tr> <tr> <th>▽▽</th> <th>H(m)</th> <th>□</th> <th>⊠</th> </tr> </thead> <tbody> <tr><td>30</td><td>57,5</td><td>9</td><td>-</td></tr> <tr><td>35</td><td>51,9</td><td>8</td><td>-</td></tr> <tr><td>40</td><td>51,9</td><td>8</td><td>-</td></tr> <tr><td>45</td><td>51,9</td><td>8</td><td>-</td></tr> <tr><td>50</td><td>46,3</td><td>7</td><td>-</td></tr> <tr><td>55</td><td>46,3</td><td>7</td><td>-</td></tr> <tr><td>60</td><td>46,3</td><td>7</td><td>-</td></tr> <tr><td>65</td><td>44,6</td><td>6</td><td>1</td></tr> </tbody> </table>	TD / 2R				▽▽	H(m)	□	⊠	30	57,5	9	-	35	51,9	8	-	40	51,9	8	-	45	51,9	8	-	50	46,3	7	-	55	46,3	7	-	60	46,3	7	-	65	44,6	6	1	<table border="1"> <thead> <tr> <th>▽▽</th> <th>H(m)</th> <th>□</th> <th>⊠</th> </tr> </thead> <tbody> <tr><td>30</td><td>51,9</td><td>8</td><td>-</td></tr> <tr><td>35</td><td>46,3</td><td>7</td><td>-</td></tr> <tr><td>40</td><td>46,3</td><td>7</td><td>-</td></tr> <tr><td>45</td><td>46,3</td><td>7</td><td>-</td></tr> <tr><td>50</td><td>46,3</td><td>7</td><td>-</td></tr> <tr><td>55</td><td>46,3</td><td>7</td><td>-</td></tr> </tbody> </table>	▽▽	H(m)	□	⊠	30	51,9	8	-	35	46,3	7	-	40	46,3	7	-	45	46,3	7	-	50	46,3	7	-	55	46,3	7	-
▽▽	H(m)	□	⊠																																																																																																							
30	57,5	9	-																																																																																																							
35	51,9	8	-																																																																																																							
40	51,9	8	-																																																																																																							
45	51,9	8	-																																																																																																							
50	51,9	8	-																																																																																																							
55	46,3	7	-																																																																																																							
60	46,3	7	-																																																																																																							
65	44,6	6	1																																																																																																							
TD / 2R																																																																																																										
▽▽	H(m)	□	⊠																																																																																																							
30	57,5	9	-																																																																																																							
35	51,9	8	-																																																																																																							
40	51,9	8	-																																																																																																							
45	51,9	8	-																																																																																																							
50	46,3	7	-																																																																																																							
55	46,3	7	-																																																																																																							
60	46,3	7	-																																																																																																							
65	44,6	6	1																																																																																																							
▽▽	H(m)	□	⊠																																																																																																							
30	51,9	8	-																																																																																																							
35	46,3	7	-																																																																																																							
40	46,3	7	-																																																																																																							
45	46,3	7	-																																																																																																							
50	46,3	7	-																																																																																																							
55	46,3	7	-																																																																																																							

⊠ TSR20
 □ TSR20-5,6

(H) TRASLACIÓN / TRAVELLING / TRASLATION / ПЕРЕМЕЩЕНИЕ / RAY YÜRÜYÜŞLÜ / متحركة

TD	TD / 2R / 3R		3R																																																																																																							
<table border="1" style="margin-top: 10px;"> <thead> <tr> <th>▽▽</th> <th>H(m)</th> <th>□</th> <th>⊠</th> </tr> </thead> <tbody> <tr><td>30</td><td>58,2</td><td>9</td><td>-</td></tr> <tr><td>35</td><td>52,6</td><td>8</td><td>-</td></tr> <tr><td>40</td><td>52,6</td><td>8</td><td>-</td></tr> <tr><td>45</td><td>52,6</td><td>8</td><td>-</td></tr> <tr><td>50</td><td>52,6</td><td>8</td><td>-</td></tr> <tr><td>55</td><td>47,0</td><td>7</td><td>-</td></tr> <tr><td>60</td><td>47,0</td><td>7</td><td>-</td></tr> <tr><td>65</td><td>45,3</td><td>6</td><td>-</td></tr> </tbody> </table>	▽▽	H(m)	□	⊠	30	58,2	9	-	35	52,6	8	-	40	52,6	8	-	45	52,6	8	-	50	52,6	8	-	55	47,0	7	-	60	47,0	7	-	65	45,3	6	-	<table border="1" style="margin-bottom: 10px;"> <thead> <tr> <th colspan="4">TD / 2R</th> </tr> <tr> <th>▽▽</th> <th>H(m)</th> <th>□</th> <th>⊠</th> </tr> </thead> <tbody> <tr><td>30</td><td>58,2</td><td>9</td><td>-</td></tr> <tr><td>35</td><td>52,6</td><td>8</td><td>-</td></tr> <tr><td>40</td><td>52,6</td><td>8</td><td>-</td></tr> <tr><td>45</td><td>52,6</td><td>8</td><td>-</td></tr> <tr><td>50</td><td>47,0</td><td>7</td><td>-</td></tr> <tr><td>55</td><td>47,0</td><td>7</td><td>-</td></tr> <tr><td>60</td><td>47,0</td><td>7</td><td>-</td></tr> <tr><td>65</td><td>45,3</td><td>6</td><td>1</td></tr> </tbody> </table>	TD / 2R				▽▽	H(m)	□	⊠	30	58,2	9	-	35	52,6	8	-	40	52,6	8	-	45	52,6	8	-	50	47,0	7	-	55	47,0	7	-	60	47,0	7	-	65	45,3	6	1	<table border="1"> <thead> <tr> <th>▽▽</th> <th>H(m)</th> <th>□</th> <th>⊠</th> </tr> </thead> <tbody> <tr><td>30</td><td>52,6</td><td>8</td><td>-</td></tr> <tr><td>35</td><td>47,0</td><td>7</td><td>-</td></tr> <tr><td>40</td><td>47,0</td><td>7</td><td>-</td></tr> <tr><td>45</td><td>47,0</td><td>7</td><td>-</td></tr> <tr><td>50</td><td>47,0</td><td>7</td><td>-</td></tr> <tr><td>55</td><td>47,0</td><td>7</td><td>-</td></tr> </tbody> </table>	▽▽	H(m)	□	⊠	30	52,6	8	-	35	47,0	7	-	40	47,0	7	-	45	47,0	7	-	50	47,0	7	-	55	47,0	7	-
▽▽	H(m)	□	⊠																																																																																																							
30	58,2	9	-																																																																																																							
35	52,6	8	-																																																																																																							
40	52,6	8	-																																																																																																							
45	52,6	8	-																																																																																																							
50	52,6	8	-																																																																																																							
55	47,0	7	-																																																																																																							
60	47,0	7	-																																																																																																							
65	45,3	6	-																																																																																																							
TD / 2R																																																																																																										
▽▽	H(m)	□	⊠																																																																																																							
30	58,2	9	-																																																																																																							
35	52,6	8	-																																																																																																							
40	52,6	8	-																																																																																																							
45	52,6	8	-																																																																																																							
50	47,0	7	-																																																																																																							
55	47,0	7	-																																																																																																							
60	47,0	7	-																																																																																																							
65	45,3	6	1																																																																																																							
▽▽	H(m)	□	⊠																																																																																																							
30	52,6	8	-																																																																																																							
35	47,0	7	-																																																																																																							
40	47,0	7	-																																																																																																							
45	47,0	7	-																																																																																																							
50	47,0	7	-																																																																																																							
55	47,0	7	-																																																																																																							

⊠ TSR20
 □ TSR20-5,6

H =

Máxima altura de torre sin arriostrar (m).
 Maximum tower height without fastening (m).
 Hauteur maximale de tour sans ancrage (m).
 Максимальная высота башни без крепления (м).
 Desteksiz maksimum kule yüksekliği (m).
 أقصى ارتفاع للبرج بدون ربط (م)



Fecha / Date: 05/07/2021



FEM 1005 - C25

Reservado el derecho a modificaciones sin previo aviso. Declinamos toda responsabilidad derivada de la información proporcionada / Subject to modification, without prior notice. This information is supplied without liability / L'entreprise se réserve le droit de procéder à des modifications sans préavis. Nous déclinons toute responsabilité quant aux informations fournies / Мы оставляем за собой право на внесение изменений без предварительного уведомления. Мы снимаем с себя любую ответственность в отношении предоставленной информации / Önceden bildirilmeksizin değiştirilme hakkı saklıdır. Verilen bilgiler için hiçbir sorumluluk kabul etmemekteyiz. حقوق التغيير محفوظة دون إشعار مسبق. دون أدنى مسؤولية عن المعلومات المقدمة

TRANSPORTE / TRANSPORT / TRANSPORT / ТРАНСПОРТИРОВКА / TAŞIMA / نقل

J480PA

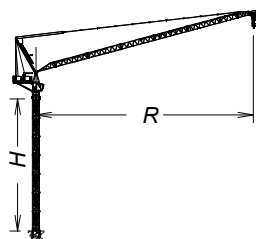

8 x



7 x HIGH CUBE 40'

1 x OPEN TOP 40'

R = 65 m, H = 39,5 m +  + ASRD20/24

TREPADO / CLIMBING / TÉLESCOPAGE / ЛЕСТНИЦА / TIRMANMA / التسلق

J480PA

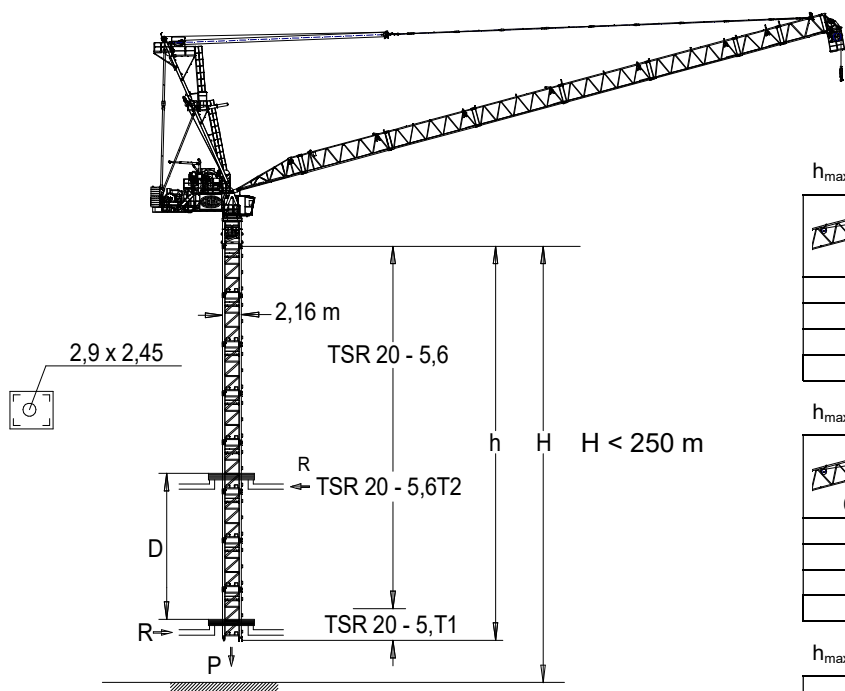

$h_{max} = \text{TSR20-5,6T1} + 5 \times \text{TSR20-5,6} + \text{TSR 20-5,6T2}$

	TD 12 t	▶	■
65 m.			
h (m)		39,2	
D (m)		18 – 15	
P (KN)		1755	1635
Rmax (KN)		435	835

$h_{max} = \text{TSR20-5,6T1} + 5 \times \text{TSR 20-5,6} + \text{TSR 20-5,6T2}$

	TD/2R/3R TD/2R 24 t	▶	■
60 m.			
h (m)		39,2	
D (m)		18 – 15,6	
P (KN)		1865	1625
Rmax (KN)		450	820

$h_{max} = \text{TSR20-5,6T1} + 5 \times \text{TSR20-5,6} + \text{TSR20-5,6T2}$

	TD/2R/3R 3R 36 t	▶	■
50 m.			
h (m)		39,2	
D (m)		18 – 15,2	
P (KN)		1960	1600
Rmax (KN)		455	825

TSR20-5,6T1: 204.31.600
TSR20-5,6T2: 204.31.900

 Trepado interno / Internal climbing. / Télescopage intérieure /
Внутренняя лестница / Bina içi tirmanma / التسلق الداخلي

Fecha / Date: 05/07/2021

 **FEM 1005 - C25**



Reservado el derecho a modificaciones sin previo aviso. Declinamos toda responsabilidad derivada de la información proporcionada / Subject to modification, without prior notice. This information is supplied without liability /
L'entreprise se réserve le droit de procéder à des modifications sans préavis. Nous déclinons toute responsabilité quant aux informations fournies / Мы оставляем за собой право на внесение изменений без предварительного уведомления. Мы снимаем с себя любую ответственность в отношении предоставленной информации / Önceden bildirilmeksizin değiştirilme hakkı saklıdır. Verilen bilgiler için hiçbir sorumluluk kabul etmemekteyiz
حقوق التغيير محفوظة دون إشعار مسبق. دون أدنى مسؤولية عن المعلومات المقدمة

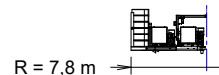

(H) ESTACIONARIA / STATIONARY / STATIONAIRE / СТАЦИОНАРНОЕ СОСТОЯНИЕ / SABIT / ثابتة

TD

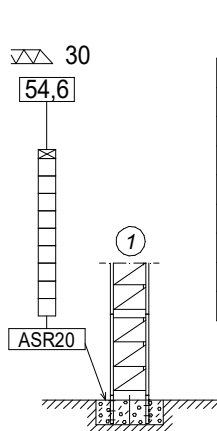

▽▽	H(m)	□	⊠
30	54,6	9	1
35	50,7	9	-
40	50,7	9	-
45	45,1	8	-
50	45,1	8	-
55	45,1	8	-
60	43,4	7	1
65	39,5	7	-

▽▽	H(m)	⊠	▨	□	⊠
30	63,3	3	1	8	-
35	57,7	2	1	8	-
40	57,7	3	1	7	-
45	56,0	2	1	7	1
50	52,1	2	1	7	-
55	52,1	3	1	6	-
60	50,4	3	1	5	1
65	46,5	2	1	6	-

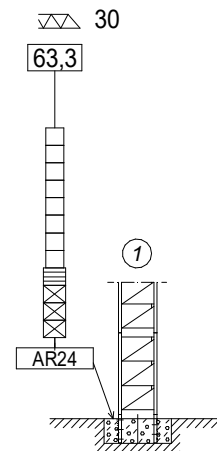

- ⊠ TSR20
- TSR20-5,6
- ▨ TR24/TSR20
- ⊠ TR24-5,6

TD / 2R / 3R

TD / 2R			
▽▽	H(m)	□	⊠
30	49,0	8	1
35	45,1	8	-
40	45,1	8	-
45	45,1	8	-
50	43,4	7	1
55	39,5	7	-
60	37,8	6	1
65	37,8	6	1

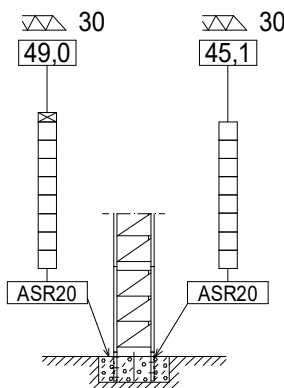

3R			
▽▽	H(m)	□	⊠
30	45,1	8	-
35	39,5	7	-
40	39,5	7	-
45	39,5	7	-
50	39,5	7	-
55	39,5	7	-

- ⊠ TSR20
- TSR20-5,6
- ▨ TR24/TSR20
- ⊠ TR24-5,6

TD / 2R					
▽▽	H(m)	⊠	▨	□	⊠
30	63,3	3	1	8	-
35	61,6	4	1	6	1
40	57,7	3	1	7	-
45	56,0	3	1	6	1
50	52,1	2	1	7	-
55	52,1	3	1	6	-
60	50,4	3	1	5	1
65	46,5	2	1	6	-

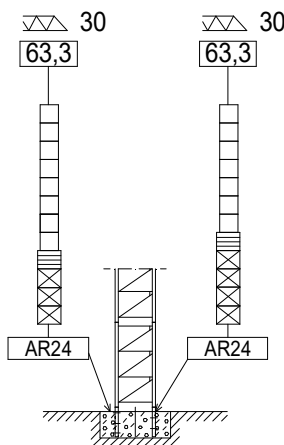

3R					
▽▽	H(m)	⊠	▨	□	⊠
30	63,3	4	1	7	-
35	61,6	5	1	5	1
40	57,7	4	1	6	-
45	56,0	3	1	6	1
50	52,1	3	1	6	-
55	52,1	3	1	6	-

H = Máxima altura de torre sin arriostrar (m).
 Maximum tower height without fastening (m).
 Hauteur maximale de tour sans ancrage (m).
 Максимальная высота башни без крепления (m).
 Desteksiz maksimum kule yüksekliği (m)
 أقصى ارتفاع للبرج بدون ربط (م)



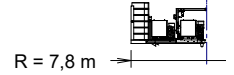

(H) ESTACIONARIA 3 / STATIONARY 3 / STATIONAIRE / СТАЦИОНАРНОЕ СОСТОЯНИЕ / SABIT / ثابتة

TD				TD/2R/3R																																																																			
	∇/∇	H(m)	<input type="checkbox"/>	<input checked="" type="checkbox"/>																																																																			
	30	51,9	8	-																																																																			
	35	51,9	8	-																																																																			
	40	51,9	8	-																																																																			
	45	50,2	7	1																																																																			
	50	46,3	7	-																																																																			
	55	46,3	7	-																																																																			
	60	46,3	7	-																																																																			
65	44,6	6	1																																																																				
<table border="1"> <thead> <tr> <th>∇/∇</th> <th>H(m)</th> <th><input type="checkbox"/></th> <th><input checked="" type="checkbox"/></th> </tr> </thead> <tbody> <tr><td>30</td><td>51,9</td><td>8</td><td>-</td></tr> <tr><td>35</td><td>51,9</td><td>8</td><td>-</td></tr> <tr><td>40</td><td>51,9</td><td>8</td><td>-</td></tr> <tr><td>45</td><td>51,9</td><td>8</td><td>-</td></tr> <tr><td>50</td><td>46,3</td><td>7</td><td>-</td></tr> <tr><td>55</td><td>46,3</td><td>7</td><td>-</td></tr> <tr><td>60</td><td>44,6</td><td>6</td><td>1</td></tr> <tr><td>65</td><td>44,6</td><td>6</td><td>1</td></tr> </tbody> </table>				∇/∇	H(m)	<input type="checkbox"/>	<input checked="" type="checkbox"/>	30	51,9	8	-	35	51,9	8	-	40	51,9	8	-	45	51,9	8	-	50	46,3	7	-	55	46,3	7	-	60	44,6	6	1	65	44,6	6	1	<table border="1"> <thead> <tr> <th>∇/∇</th> <th>H(m)</th> <th><input type="checkbox"/></th> <th><input checked="" type="checkbox"/></th> </tr> </thead> <tbody> <tr><td>30</td><td>51,9</td><td>8</td><td>-</td></tr> <tr><td>35</td><td>46,3</td><td>7</td><td>-</td></tr> <tr><td>40</td><td>46,3</td><td>7</td><td>-</td></tr> <tr><td>45</td><td>46,3</td><td>7</td><td>-</td></tr> <tr><td>50</td><td>46,3</td><td>7</td><td>-</td></tr> <tr><td>55</td><td>46,3</td><td>7</td><td>-</td></tr> </tbody> </table>				∇/∇	H(m)	<input type="checkbox"/>	<input checked="" type="checkbox"/>	30	51,9	8	-	35	46,3	7	-	40	46,3	7	-	45	46,3	7	-	50	46,3	7	-	55	46,3	7	-
∇/∇	H(m)	<input type="checkbox"/>	<input checked="" type="checkbox"/>																																																																				
30	51,9	8	-																																																																				
35	51,9	8	-																																																																				
40	51,9	8	-																																																																				
45	51,9	8	-																																																																				
50	46,3	7	-																																																																				
55	46,3	7	-																																																																				
60	44,6	6	1																																																																				
65	44,6	6	1																																																																				
∇/∇	H(m)	<input type="checkbox"/>	<input checked="" type="checkbox"/>																																																																				
30	51,9	8	-																																																																				
35	46,3	7	-																																																																				
40	46,3	7	-																																																																				
45	46,3	7	-																																																																				
50	46,3	7	-																																																																				
55	46,3	7	-																																																																				

TSR20
 TSR20-5,6

(H) TRASLACIÓN / TRAVELLING / TRASLATION / ПЕРЕМЕЩЕНИЕ / RAY YÜRÜYÜŞLÜ / متحركة

TD				TD / 2R / 3R																																																																			
	∇/∇	H(m)	<input type="checkbox"/>	<input checked="" type="checkbox"/>																																																																			
	30	52,6	8	-																																																																			
	35	52,6	8	-																																																																			
	40	52,6	8	-																																																																			
	45	50,9	7	1																																																																			
	50	47,0	7	-																																																																			
	55	47,0	7	-																																																																			
	60	47,0	7	-																																																																			
65	45,3	6	1																																																																				
<table border="1"> <thead> <tr> <th>∇/∇</th> <th>H(m)</th> <th><input type="checkbox"/></th> <th><input checked="" type="checkbox"/></th> </tr> </thead> <tbody> <tr><td>30</td><td>52,6</td><td>8</td><td>-</td></tr> <tr><td>35</td><td>52,6</td><td>8</td><td>-</td></tr> <tr><td>40</td><td>52,6</td><td>8</td><td>-</td></tr> <tr><td>45</td><td>52,6</td><td>8</td><td>-</td></tr> <tr><td>50</td><td>47,0</td><td>7</td><td>-</td></tr> <tr><td>55</td><td>47,0</td><td>7</td><td>-</td></tr> <tr><td>60</td><td>45,3</td><td>6</td><td>1</td></tr> <tr><td>65</td><td>45,3</td><td>6</td><td>1</td></tr> </tbody> </table>				∇/∇	H(m)	<input type="checkbox"/>	<input checked="" type="checkbox"/>	30	52,6	8	-	35	52,6	8	-	40	52,6	8	-	45	52,6	8	-	50	47,0	7	-	55	47,0	7	-	60	45,3	6	1	65	45,3	6	1	<table border="1"> <thead> <tr> <th>∇/∇</th> <th>H(m)</th> <th><input type="checkbox"/></th> <th><input checked="" type="checkbox"/></th> </tr> </thead> <tbody> <tr><td>30</td><td>52,6</td><td>8</td><td>-</td></tr> <tr><td>35</td><td>47,7</td><td>7</td><td>-</td></tr> <tr><td>40</td><td>47,0</td><td>7</td><td>-</td></tr> <tr><td>45</td><td>47,0</td><td>7</td><td>-</td></tr> <tr><td>50</td><td>47,0</td><td>7</td><td>-</td></tr> <tr><td>55</td><td>47,0</td><td>7</td><td>-</td></tr> </tbody> </table>				∇/∇	H(m)	<input type="checkbox"/>	<input checked="" type="checkbox"/>	30	52,6	8	-	35	47,7	7	-	40	47,0	7	-	45	47,0	7	-	50	47,0	7	-	55	47,0	7	-
∇/∇	H(m)	<input type="checkbox"/>	<input checked="" type="checkbox"/>																																																																				
30	52,6	8	-																																																																				
35	52,6	8	-																																																																				
40	52,6	8	-																																																																				
45	52,6	8	-																																																																				
50	47,0	7	-																																																																				
55	47,0	7	-																																																																				
60	45,3	6	1																																																																				
65	45,3	6	1																																																																				
∇/∇	H(m)	<input type="checkbox"/>	<input checked="" type="checkbox"/>																																																																				
30	52,6	8	-																																																																				
35	47,7	7	-																																																																				
40	47,0	7	-																																																																				
45	47,0	7	-																																																																				
50	47,0	7	-																																																																				
55	47,0	7	-																																																																				

TSR20
 TSR20-5,6

H = Máxima altura de torre sin arriostrar (m).
Maximum tower height without fastening (m).
Hauteur maximale de tour sans ancrage (m).
Максимальная высота башни без крепления (m).
Desteksiz maksimum kule yüksekliği (m)
أقصى ارتفاع للبرج بدون ربط (م)



Fecha / Date: 05/07/2021

FEM 1005 - C25

Reservado el derecho a modificaciones sin previo aviso. Declinamos toda responsabilidad derivada de la información proporcionada / Subject to modification, without prior notice. This information is supplied without liability / L'entreprise se réserve le droit de procéder à des modifications sans préavis. Nous déclinons toute responsabilité quant aux informations fournies / Мы оставляем за собой право на внесение изменений без предварительного уведомления. Мы снимаем с себя любую ответственность в отношении предоставленной информации / Önceden bildirilmeksizin değiştirilme hakkı saklıdır. Verilen bilgiler için hiçbir sorumluluk kabul etmemekteyiz. حقوق التغيير محفوظة دون إشعار مسبق. دون أدنى مسؤولية عن المعلومات المقدمة

TRANSPORTE / TRANSPORT / TRANSPORT / ТРАНСПОРТИРОВКА / TAŞIMA / نقل

J480PA

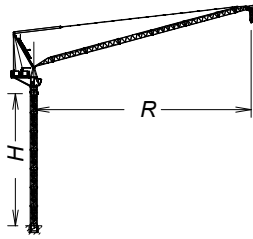

R = 65 m, H = 39,5 m +  + ASRD20/24



8 x

9 x HIGH CUBE 40'

1 x OPEN TOP 40'

TREPADO / CLIMBING / TÉLESCOPAGE / ЛЕСТНИЦА / TIRMANMA / التسلق

J480PA

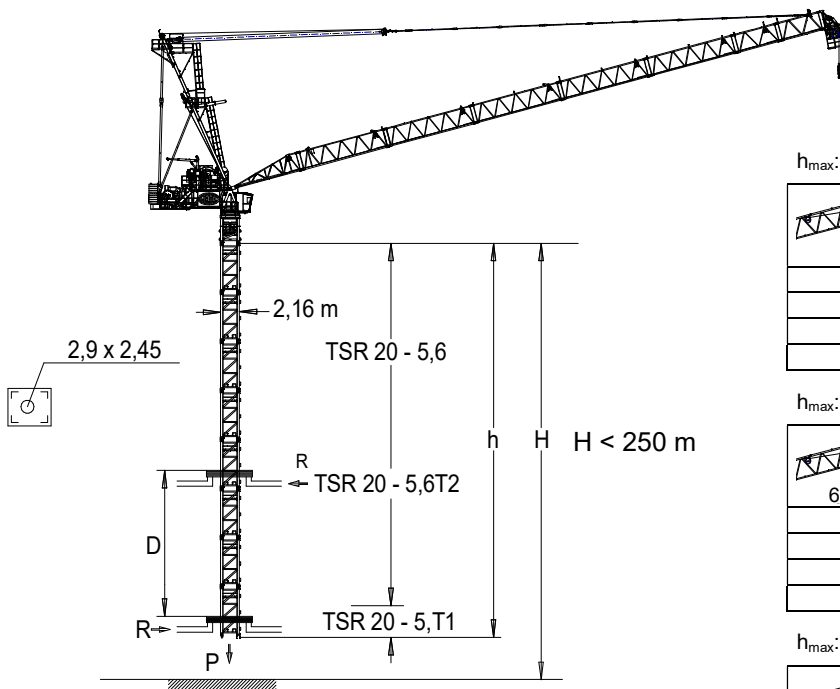

TSR20-5,6T1: 204.31.600
TSR20-5,6T2: 204.31.900



Trepado interno / Internal climbing. / *Télescopage intérieur* / *Внутренняя лестница / Bina içi tirmanma / التسلق الداخلي*

h_{max} : TSR20-5,6T1 + 5 x TSR20-5,6 + TSR 20-5,6T2

	TD 12 t	▶	■
65 m. →			
h (m)		39,2	
D (m)		18 – 15,2	
P (kN)		1730	1610
Rmax (kN)		435	835

h_{max} : TSR20-5,6T1 + 4 x TSR 20-5,6 + TSR 20-5,6T2 + TSR20

	TD/2R/3R TD/2R 24 t	▶	■
60 m. →			
h (m)		37,5	
D (m)		17 – 15,1	
P (kN)		1835	1595
Rmax (kN)		460	825

h_{max} : TSR20-5,6T1 + 5 x TSR20-5,6 + TSR20-5,6T2

	TD/2R/3R 3R 36 t	▶	■
50 m. →			
h (m)		39,2	
D (m)		18 – 15,4	
P (kN)		1870	1510
Rmax (kN)		450	820

Fecha / Date: 05/07/2021

 **FEM 1005 - C25**



Reservado el derecho a modificaciones sin previo aviso. Declinamos toda responsabilidad derivada de la información proporcionada / Subject to modification, without prior notice. This information is supplied without liability / L'entreprise se réserve le droit de procéder à des modifications sans préavis. Nous déclinons toute responsabilité quant aux informations fournies / Мы оставляем за собой право на внесение изменений без предварительного уведомления. Мы снимаем с себя любую ответственность в отношении предоставленной информации / Önceden bildirilmeksizin değiştirilme hakkı saklıdır. Verilen bilgiler için hiçbir sorumluluk kabul etmemekteyiz / حقوق التغيير محفوظة دون إشعار مسبق. دون أدنى مسؤولية عن المعلومات المقدمة

LISTA DE EMBARQUE / PACKING LIST LISTE DE COLISAGE / СПИСОК ПОСТАВКИ / ÇEKİ LİSTESİ / قائمة التحميل J480PA

DENOMINACIÓN / DENOMINATION / DÉSIGNATION / НАЗВАНИЕ / AÇIKLAMA / اسم		L [m]	A [m]	H [m]	P / W [kg]	
Torre inferior / Lower tower / Tour inférieure / Нижняя башня Alt kule / البرج السفلي	TSRI-20-5,6		5,990	2,257	2,257	6562
Torre / Tower / Tour Башня / Kule / برج	TSR20 TSR20-5,6		4,260 5,990	2,251 2,257	2,251 2,257	3110 4210
Torre asiento pista, torre superior y orientación Slewing table, top tower and slewing mechanism Tour pivot + tour supérieure + mécanisme d'orientation Сиденье площадки + верхняя башня + поворотный механизм Göbek + üst kule + mekanizma برج وحدة الدوران + البرج العلوي + آلية الدوران			9,650	2,320	2,560	15825
Punta de torre / Top tower tour supérieure / верхняя башня / Kulenin kafa bölümü / رأس البرج			5,860	2,280	2,380	5300
Torre asiento pista + base punta de torre + orientación Slewing table + tower head base + slewing mechanism Tour pivot + base du porte-flèche + mécanisme d'orientation Сиденье площадки + основание верхней секции башни + поворотный механизм Göbek + üst kule + mekanizma برج وحدة الدوران + البرج العلوي + آلية الدوران			4,660	2,560	2,460	10525
Tramo de pluma Jib section Tronçon de flèche Секция стрелы Vom bölümü أجزاء الذراع	[1] [2] [3] [4] [5] [6] [7] [8] [9-3R]		6,265 10,460 10,505 10,550 10,550 10,550 5,615 3,780 2,370	2,200 1,560 1,560 1,540 1,490 1,540 1,540 1,540 1,970	1,783 1,750 1,748 1,752 1,730 1,725 1,725 1,855 3,17	1830 2710 2630 2295 1890 1745 980 995 1105
Contrapluma con mecanismos, pasteca y plumin Counterjib with mechanisms, reeving block and auxiliary jib Contre-flèche avec mécanismes et fléchette auxiliaire Противовесная консоль с механизмами и вспомогательной дополнительной стрелой Mekanizmalı kuiruk ve yardımcı kol uzantısı الذراع المعاكس مع اليات وريشة مساعدة			7,300	2,241	2,495	19600
Contrapluma con elevacion pluma, pasteca y plumin Counterjib with luffing mechanisms, reeving block and auxiliary jib Contre-flèche avec mécanisme de relevage de la flèche, moufle et fléchette Противовесная консоль с механизмом подъема стрелы, блоком и дополнительной стрелой Kaldırma kolu, makara düzenekli ve kol uzantılı kuiruk الذراع المعاكس مع رافع الذراع والبكرة والريشة الإضافية			7,300	2,218	2,495	12700
Mecanismo elevacion carga / Hoisting mechanism / Mécanisme de levage de charge / Подъем груза / Yük kaldırma / رافع الحمولة			2,208	2,539	2,068	6900
Polipasto / Hook assembly / Palan / Полуснаст / Kanca takımı / بكرة	TD/2R/3R TD		1,101 0,150	0,340 0,278	1,692 1,715	800 240
Tirante sostén pluma / Jib support tie / Tirant de fleche Растяжка поддержки стрелы / Kol destek bağları / مشد دعامة الذراع			5,850	0,430	0,615	2375
Parte superior Top part			11,947	2,222	0,878	6970
Plataforma y cabina (2 x 1,5) / Platform and cabin / Plateforme et cabine / Платформа и кабина / Platform ve kabin / منصة وكابينة			3,670	2,300	2,480	1250
Transporte torre de montaje / Jacking cage transport / Transport de tour de montage / Транспортировка монтажной башни / Kaldırma kafesinin taşınması / نقل برج التركيب	TM20PASR-5,6		10,820	2,285	2,395	12140
Contrapeso / Counterweight Contrepoids / Противовес / Denge ağırlığı / اوزان معاكسة			2,200 4,500	0,340	0,830	3000 6000
Contrapeso / Counterweight / Contrepoids / Противовес / Denge ağırlığı / اوزان معاكسة	Lastre / Ballast / Lest / Балласт Alt ağırlık taşları / ثقلي		3,8 3,8	0,275 0,580	1,5 1,5	3000 6000



Ctra./Rd. Madrid - Iruñ Km. 415 - 20.213 IDIAZABAL [Gipuzkoa] ESPAÑA / SPAIN
P.O. Box, 23 - 20.200 BEASAIN - E-mail: jaso@jaso.com
Tel. +34 943 - 18 70 00 • Fax. +34 943 - 18 70 20
www.jaso.com

Fecha / Date: 05/07/2021

FEM 1005 - C25

DELEGACION / DEALER

Reservado el derecho a modificaciones sin previo aviso. Declinamos toda responsabilidad derivada de la información proporcionada / Subject to modification, without prior notice.
This information is supplied without liability / L'entreprise se réserve le droit de procéder à des modifications sans préavis. Nous déclinons toute responsabilité quant aux informations
fournies / Мы оставляем за собой право на внесение изменений без предварительного уведомления. Мы снимаем с себя любую ответственность в отношении
предоставленной информации / Önceden bildirilmeksizin değiştirilme hakkı saklıdır. Verilen bilgiler için hiçbir sorumluluk kabul etmemekteyiz /

حقوق التغيير محفوظة دون إشعار مسبق دون أدنى مسؤولية عن المعلومات المقدمة