

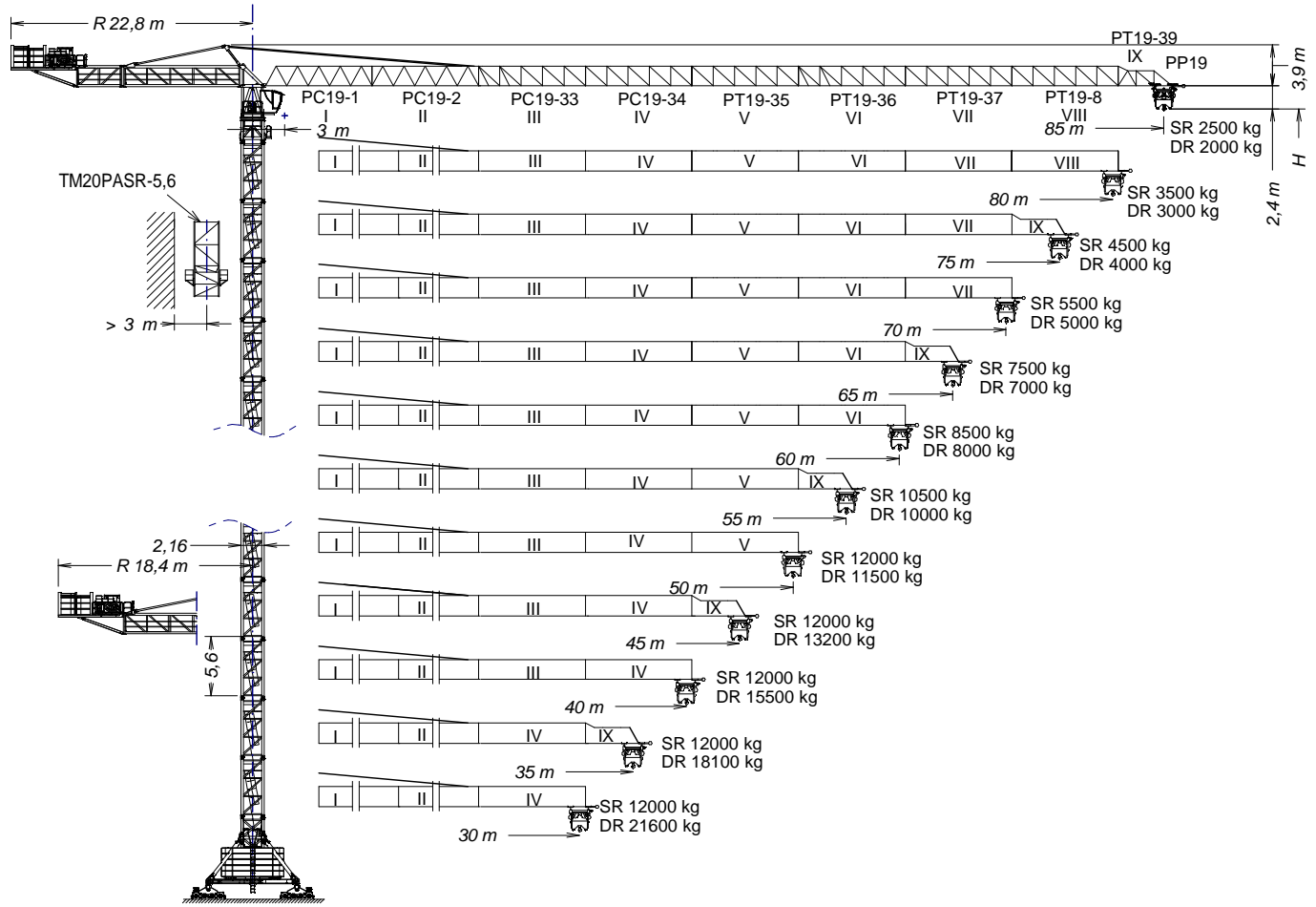

EN 14439
C25

UNE-EN-ISO 9001



H =

Altura máxima bajo gancho sin arriostrar (m).
 Maxim height under hook without fastening (m).
 Hauteur maximale sous crochet sans ancrage (m).
 Максимальная высота под крюком без крепления (m).
 Bağlantısız maksimum kanca altı yüksekliği (m).
 أقصى ارتفاع تحت الخطاف بدون ربط (m)

PC19-1	163.40.000	BSRI 8-20-5,6	204.20.000
PC19-2	163.41.000	BRI 10-24	156.20.500
PC19-33	163.42.500	ASR20	160.21.200
PC19-34	163.43.500	ASRD 20/24	156.21.000
PT19-35	163.44.500	TSR20	153.31.800
PT19-36	163.45.500	TSR20-5,6	204.31.000
PT19-37	163.46.500	TR24/TSR20	204.36.000
PT19-8	163.47.000	TR24-5,6	156.30.700
PT19-39	163.48.200	TRD24-5,6	163.31.300
PP19	163.48.500	TM20PASR-5,6	206.35.000
		ABH100B	204.23.000
		ABH100H	156.23.500

(H) TRASLACIÓN / TRAVELLING /
 TRASLATION / ПЕРЕМЕЩЕНИЕ / RAY YÜRÜYÜŞLÜ / متحركة

(H) ESTACIONARIA / STATIONARY /
 STATIONAIRE / СТАЦИОНАРНОЕ СОСТОЯНИЕ / SABIT / ثابتة

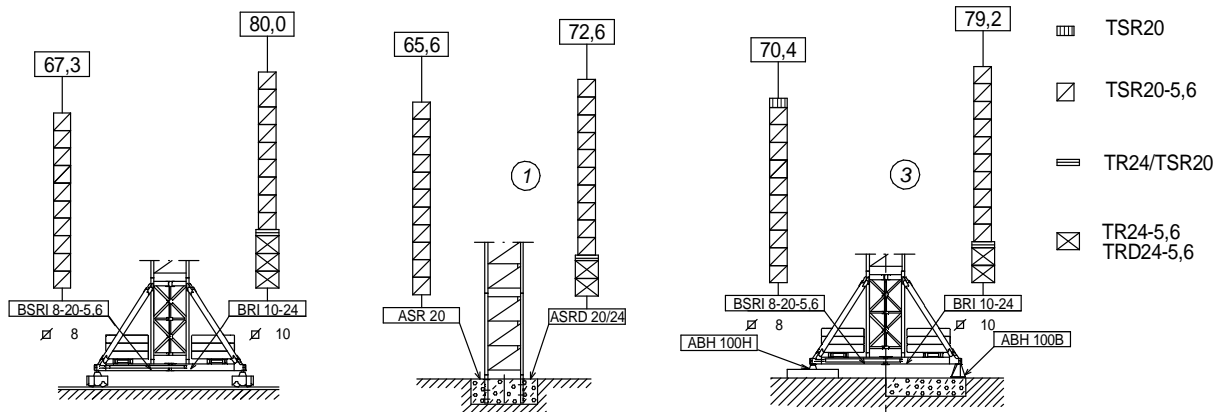

Fecha / Date: 20/01/2016

FEM 1005 - C25



Reservado el derecho a modificaciones sin previo aviso. Declinamos toda responsabilidad derivada de la información proporcionada / Subject to modification, without previous warning. This information is supplied without liability / L'entreprise se réserve le droit de procéder à des modifications sans préavis. Nous déclinons toute responsabilité quant aux informations fournies / Мы оставляем за собой право на внесение изменений без предварительного уведомления. Мы снимаем с себя любую ответственность в отношении предоставленной информации / Önceden bildirilmeksizin değiştirilme hakkı saklıdır. Verilen bilgiler için hiçbir sorumluluk kabul etmemekteyiz / حقوق التغيير محفوظة دون إشعار مسبق. دون أدنى مسؤولية عن المعلومات المقدمة

CARGAS / LOADS / CHARGES / НАГРУЗКИ / YÜKLER / الأحمال **J560**

 ST-SR (kg)		Cargas máximas / Maximum loads / Charges maximales / Максимальные нагрузки / Maksimum yük / أقصى حمولة ST - SR - 12 t													
 [m]	12 t @ ... (m)	Alcance del gancho [m] / Hook reach [m] / Portée du crochet (m) / Радиус действия крюка (m) / Kancanın yüksekliği (m) / مدى الخطاف													
		25	30	35	40	45	50	55	60	65	70	75	80	85	
85	27,6	12,00	10,87	9,02	7,64	6,56	5,70	4,99	4,40	3,90	3,48	3,11	2,78	2,5	
80	31,7	12,00	12,00	10,66	9,07	7,83	6,84	6,03	5,36	4,78	4,29	3,87	3,50	—	
75	35,0	12,00	12,00	12,00	10,25	8,88	7,78	6,89	6,14	5,51	4,97	4,50	—	—	
70	37,7	12,00	12,00	12,00	11,17	9,70	8,53	7,56	6,76	6,08	5,50	—	—	—	
65	44,2	12,00	12,00	12,00	12,00	11,75	10,37	9,24	8,30	7,50	—	—	—	—	
60	45,1	12,00	12,00	12,00	12,00	12,00	10,61	9,46	8,50	—	—	—	—	—	
55	49,1	12,00	12,00	12,00	12,00	12,00	11,76	10,50	—	—	—	—	—	—	
50	50,0	12,00	12,00	12,00	12,00	12,00	12,00	—	—	—	—	—	—	—	
45	45,0	12,00	12,00	12,00	12,00	12,00	—	—	—	—	—	—	—	—	
40	40,0	12,00	12,00	12,00	12,00	—	—	—	—	—	—	—	—	—	
35	35,0	12,00	12,00	12,00	—	—	—	—	—	—	—	—	—	—	
30	30,0	12,00	12,00	—	—	—	—	—	—	—	—	—	—	—	

 ST - DR [t]		Cargas máximas / Maximum loads / Charges maximales / Максимальные нагрузки / Maksimum yük / أقصى حمولة ST - DR - 24 t													
 [t]	24 t @...[m]	A Alcance del gancho [m] / Hook reach [m] / Portée du crochet (m) / Радиус действия крюка (m) / Kancanın yüksekliği (m) / مدى الخطاف													
		20	25	30	35	40	45	50	55	60	65	70	75	80	85
85	14,8	17,03	13,10	10,48	8,60	7,20	6,11	5,24	4,52	3,93	3,42	2,99	2,62	2,29	2,0
80	16,9	19,87	15,37	12,37	10,23	8,62	7,37	6,37	5,56	4,87	4,30	3,80	3,37	3,00	—
75	18,7	22,21	17,25	13,93	11,57	9,79	8,42	7,31	6,41	5,66	5,02	4,47	4,00	—	—
70	20,0	24,00	18,72	15,16	12,62	10,72	9,23	8,05	7,08	6,27	5,59	5,00	—	—	—
65	23,5	24,00	22,40	18,23	15,25	13,01	11,28	9,89	8,75	7,80	7,00	—	—	—	—
60	23,9	24,00	22,87	18,62	15,59	13,31	11,54	10,12	8,97	8,00	—	—	—	—	—
55	26,1	24,00	24,00	20,52	17,21	14,73	12,80	11,26	10,00	—	—	—	—	—	—
50	26,5	24,00	24,00	20,92	17,55	15,03	13,07	11,50	—	—	—	—	—	—	—
45	26,7	24,00	24,00	21,11	17,72	15,18	13,20	—	—	—	—	—	—	—	—
40	27,2	24,00	24,00	21,54	18,09	15,50	—	—	—	—	—	—	—	—	—
35	27,2	24,00	24,00	21,55	18,10	—	—	—	—	—	—	—	—	—	—
30	27,3	24,00	24,00	21,60	—	—	—	—	—	—	—	—	—	—	—

LASTRES INFERIORES / LOWER BALLASTS / LESTS INFÉRIEURS / НИЖНИЙ БАЛЛАСТ / ALT AĞIRLIK TAŞLARI / ثقل **J560**

BRI 10-24	H (m)	74,4	80	
	P (t)	60	72	
BSRI 8-20-5,6	H (m)	56,1	61,7	70,4
	P (t)	96	108	120





H: Altura bajo gancho / Height under hook / Hauteur maximale sous crochet / Высота под крюком / Kanca altı yüksekliği / الارتفاع أسفل الخطاف
 Para alturas intermedias tomar el lastre correspondiente a la altura superior / For intermediate heights take the ballast corresponding to the higher height / Pour les hauteurs intermédiaires, opter pour le lest correspondant à la hauteur immédiatement supérieure / Для промежуточных высот возьмите балласт, соответствующий большей высоте / Orta yükseklikler için daha üst bir yüksekliğe karşılık gelen ağırlığı alıniz. / استخدام الثقل العائد للارتفاع الأعلى. / للارتفاعات البينية يرجى استخدام الثقل العائد للارتفاع الأعلى.





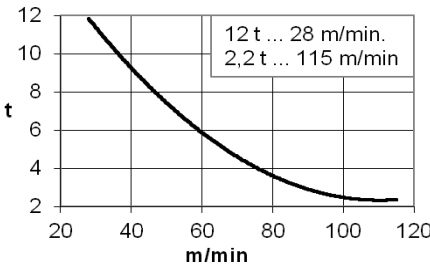
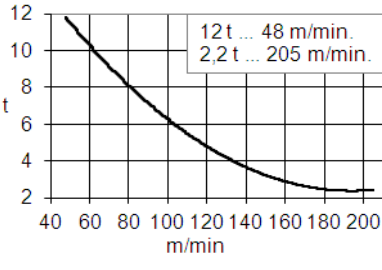
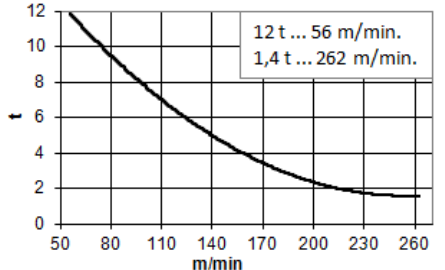

Fecha / Date: 20/01/2016

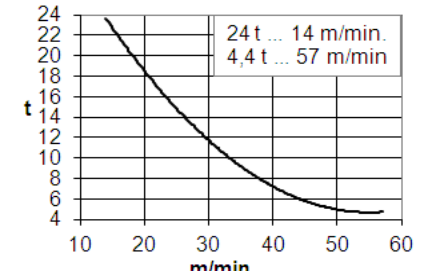
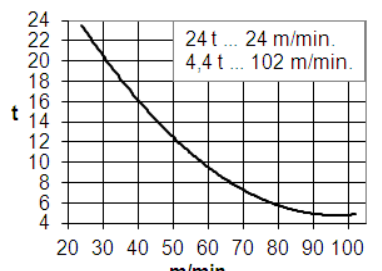
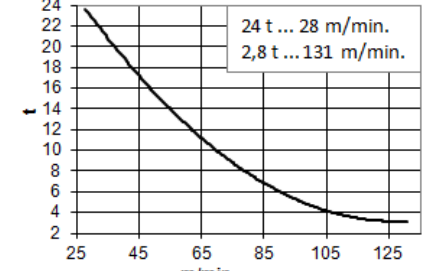
 **FEM 1005 - C25**

Reservado el derecho a modificaciones sin previo aviso. Declinamos toda responsabilidad derivada de la información proporcionada / Subject to modification, without previous warning. This information is supplied without liability / L'entreprise se réserve le droit de procéder à des modifications sans préavis. Nous déclinons toute responsabilité quant aux informations fournies / Мы оставляем за собой право на внесение изменений без предварительного уведомления. Мы снимаем с себя любую ответственность в отношении предоставленной информации / Önceden bildirilmeksizin değiştirilme hakkı saklıdır. Verilen bilgiler için hiçbir sorumluluk kabul etmemekteyiz / حقوق التغيير محفوظة دون إشعار مسبق. دون أدنى مسؤولية عن المعلومات المقدمة

*opcional *optional *en option *опция *opsiyonel *اختياري			
	EC88115VF 65 kW	*EC150205VF 110 kW	*EC180262VF 132 kW
			
			

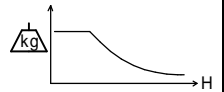
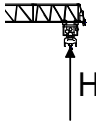
				 400V 50Hz	
TG4025VF 4 x 7,5 kW	OG4006VF 4 x 7,5 kW	TC15105VF 11 kW	TH4010 29,4 kW	P_{TOTAL}(EC88115VF + OG4006VF + TC15105VF) = 106 kW P_{TOTAL}(EC150205VF + OG4006VF + TC15105VF) = 151 Kw P_{TOTAL}(EC180262VF + OG4006VF + TC15105VF) = 173 kW	
0...25 m/min	0...0,8 r/min sl/min	12 t 0...105 m/min 24 t 0...52 m/min	0,6 m/min	 $H \leq \begin{matrix} SR \\ DR \end{matrix}$ 848m 424m	

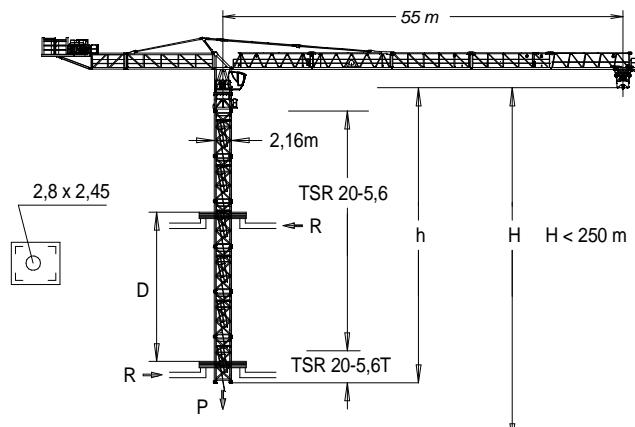





$h_{max}: \text{TSR20-5,6T} + 6 \times \text{TSR205,6}$

	▶	■	
h (m)	42,8		
D (m)	12,7 – 19		
P (KN)	1629	1389	
Rmax (KN)	369	682	

TSR20-5,6T: 204.31.700



Trepado interno / Internal climbing. / TéléscoPAGE intérieur /
 Внутренняя лестница / Bina içi tirmanma / التسلق الداخلي

- 
Viento fuera de servicio / Out of service wind / Vitesse du vent hors service / Ветровая нагрузка в покое / Rüzgar devre dışı / الريح خارج الخدمة
- 
Consultar / Consult / Nous consulter / Консультируемся / Danışınız / الرجوع إلى
- 
En servicio / In service / En service / В работе / Devrede / في الخدمة
- 
Fuera de servicio / Out of service / Hors service / В покое / Devre dışı / خارج الخدمة











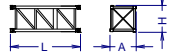
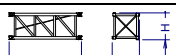
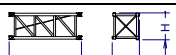

Fecha / Date: 20/01/2016

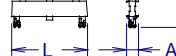
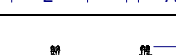
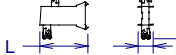
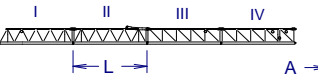

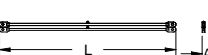
FEM 1005 - C25

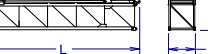
Reservado el derecho a modificaciones sin previo aviso. Declinamos toda responsabilidad derivada de la información proporcionada / Subject to modification, without previous warning. This information is supplied without liability / L'entreprise se réserve le droit de procéder à des modifications sans préavis. Nous déclinons toute responsabilité quant aux informations fournies / Мы оставляем за собой право на внесение изменений без предварительного уведомления. Мы снимаем с себя любую ответственность в отношении предоставленной информации / Onceden bildirilmeksizin değiştirilme hakkı saklıdır. Verilen bilgiler için hiçbir sorumluluk kabul etmemekteyiz / حقوق التغيير محفوظة دون إشعار مسبق. دون أدنى مسؤولية عن المعلومات المقدمة

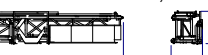
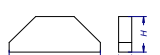
DENOMINACIÓN / DENOMINATION / DÉSIGNATION / НАЗВАНИЕ / AÇIKLAMA / اسم		L [m]	A [m]	H [m]	P / W [kg]	
Torre inferior / Lower tower / Tour inférieure / Нижняя башня Alt kule / البرج السفلي	TSRI-20-5,6		5,990	2,257	2,257	6562
	TRID24-5,6		5,990	3,203	3,203	8400
Torre / Tower / Tour Башня / Kule / برج	TSR20		4,260	2,251	2,251	3110
	TSR20-5,6		5,990	2,257	2,257	4262
	TR24-5,6		5,990	2,760	2,835	4625
Torre desmontada / Dismantled tower / Tour démontée / Разобранная башня / Kule demonte edilmiş / برج مفكك	TRD24-5,6		5,990	1,170	2,545	5156
Larguero largo, reducción / Long crossbar, reduction / Traverse longue, réduction / Длинная продольная балка, уменьшение / Uzun kiriş, azaltma عارضضة طويلة، مُصغّر	TR24/TSR20		3,950	0,6	1,814	2267
Larguero corto reducción / Short crossbar, reduction, Traverse courte, réduction / Короткая продольная балка, уменьшение / Kısa kiriş, arttırma عارضضة قصيرة، مُصغّر	TR24/TSR20		1,915	0,6	1,814	1058
Torre asiento pista, torre superior y orientación Slewing table, top tower and slewing mechanism Tour pivot + tour supérieure + mécanisme d'orientation Сиденье площадки + верхняя башня + поворотный механизм Göbek + üst kule+mekanizma برج وحدة الدوران + البرج العلوي + آلية الدوران			8,375	2,325	2,465	16900
Tramo de pluma Jib section Tronçon de flèche Секция стрелы Вом bölümü أجزاء الذراع	PC19-1		10,270	1,845	2,235	4215
	PC19-2+tr		10,300	1,600	2,400	5385
	PC19-33		10,280	1,600	2,175	4930
	PC19-34		10,280	1,600	2,175	4125
	PT19-35		10,315	1,600	2,205	2745
	PT19-36		10,300	1,600	2,205	2085
	PT19-37		10,280	1,600	2,160	1710
	PT19-8		10,280	1,600	2,160	1362
	PT19-39		5,184	1,600	2,163	770
PP19	1,300	1,850	0,655	320		
Tirante sostén pluma / Jib support tie / Tirant de fleche / Растяжка поддержки стрелы / Kol destek bağları / مشد دعامة الذراع			9,415	1,11	0,685	3225
Contrapluma III con mecanismos (sin cable) y plumín auxiliar Counterjib III with mechanism (without rope), and auxiliary jib Contre-flèche III avec mécanisme (sans cale) et fléchette auxiliaire Противовесная консоль III с механизмами (без троса) и вспомогательной дополнительной стрелой Mekanizmalı kuuyruk III (kablesiz) ve yardımcı bom uzantısı الذراع المعاكس III مع آليات (بدون كابل) وريشة مساعدة			6,395	2,300	2,456	9.620
Contrapluma II / Counterjib II / Contre-flèche II / Противовесная консоль II / Kuuyruk II / II المعاكس			4,550	2,034	2,064	2240
Contrapluma I / Counterjib I / Contre-flèche I / Противовесная консоль I / Kuuyruk I / I المعاكس			11,420	2,034	2,505	9160
Polipasto / Hook assembly / Palan / Полупаст / Kanca takımı / بكرة	ST/DR		1,750	0,650	1,340	1040
Carro / Trolley / Chariot / Грузовая тележка / Şaryo / عربة	ST/DR	P	2,580	2,305	2,135	1155
Plataforma y cabina / Platform and cabin / Plateforme et cabine / Платформа и кабина / Platform ve kabin / منصة وكابينة			4,000	1,905	2,335	1500
Transporte torre de montaje/ Jacking cage transport / Transport de tour de montage / Транспортировка монтажной башни / Kaldırma kafesinin taşınması / نقل برج التركيب	TM20PASR-5,6		10,820	2,285	2,395	12140
Contrapeso / Counterweight / Contrepoids / Противовес / Denge اوزان معاكسة / Lastre / Ballast / Lest / Балласт Alt ağırlık taşları / ثقل			3,800	0,580	1,500	6000
			3,800	0,275	1,500	3000
			3,800	0,180	1,500	2000



Ctra./Rd. Madrid - Irún Km. 415 - 20.213 IDIAZABAL [Gipuzkoa] ESPAÑA / SPAIN
P.O. Box, 23 - 20.200 BEASAIN - E-mail: jaso@jaso.com
Tel. +34 943 - 18 70 00 • Fax. +34 943 - 18 70 20
www.jaso.com

Fecha / Date: 20/01/2016

FEM 1005 - C25

DELEGACION / DEALER

Reservado el derecho a modificaciones sin previo aviso. Declinamos toda responsabilidad derivada de la información proporcionada / Subject to modification, without previous warning. This information is supplied without liability / L'entreprise se réserve le droit de procéder à des modifications sans préavis. Nous déclinons toute responsabilité quant aux informations fournies / Мы оставляем за собой право на внесение изменений без предварительного уведомления. Мы снимаем с себя любую ответственность в отношении предоставленной информации / Önceden bildirilmeksizin değiştirilme hakkı saklıdır. Verilen bilgiler için hiçbir sorumluluk kabul etmemekteyiz /

حقوق التغيير محفوظة دون إشعار مسبق. دون أدنى مسؤولية عن المعلومات المقدمة